



# DNH

HEAD OFFICE, NORWAY

**DNH AS**

Phone..... + 47 35 98 56 00

Fax..... + 47 35 98 56 10

E-mail..... dnh@dnh.no

Web-Site..... www.dnh.no

ENGLAND

**DNH WW Ltd**

Phone..... + 44 1908 275 000

Fax..... + 44 1908 275 100

E-mail..... dnh@dnh.co.uk

GERMANY

**DNH GmbH**

Phone... + 49 040 6569 30-0

Fax..... + 49 040 6569 30-30

E-mail..... dnh@dnh.de

USA

**DNH Speakers Inc**

Phone..... + 1 484 494 5790

Fax..... + 1 484 494 5793

E-mail..... dnh@dnhspeakers.com

## CW-4(T)

ISO 9001 CERTIFIED

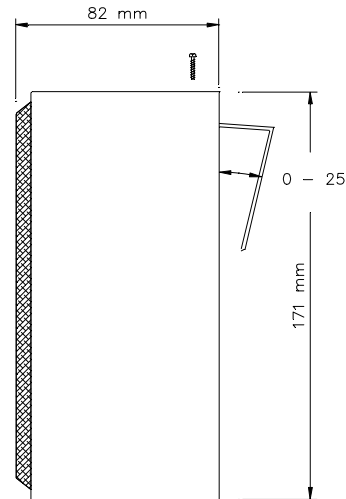
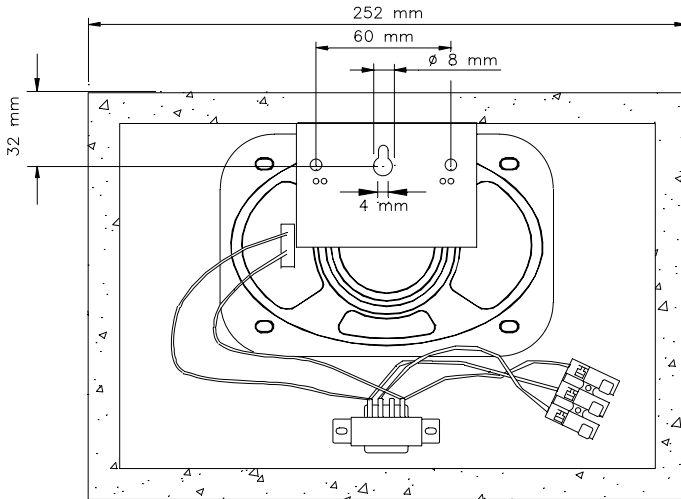

**CIRCUIT DIAGRAM**

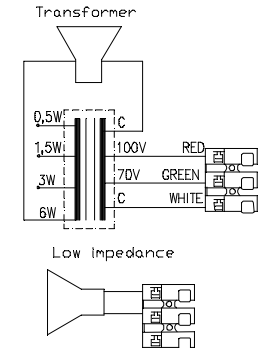

| 70/100 Volt combined transformer<br>Primary connections |       |
|---|-------|
| White : Green   | 70 V  |
| White : Red   | 100 V |
| Secondary nominal tapings                               |       |
| C : 6   | 6,0 W |
| C : 3   | 3,0 W |
| C : 1,5   | 1,5 W |
| C : 0,5   | 0,5 W |

**Sound pressure levels at 1W/1m w/P-4x6 closed**  
**SPL vs Freq**

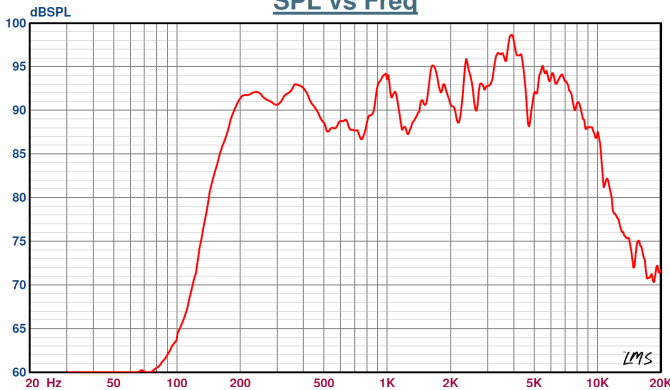

**Specifications**

|                               |                        |
|-------------------------------|------------------------|
| Material / Color              | Particle board /walnut |
| Mounting                      | Screws, keyhole        |
| Termination                   | Spring clamps          |
| Weight w/transformer          | 1,25 kg                |
| IP-rating                     | NA                     |
| Max. / min. amb. temp         | 90°C / -20°C           |
| Rated power                   | 6W                     |
| SPL 1W/1m                     | 90 dB                  |
| SPL rated power               | 97 dB                  |
| Effective freq. range         | 150 – 15000 Hz         |
| Dispersion (-6dB) 1kHz / 4kHz | 140° / 120°            |
| Options                       | Impedances, labels     |

**Installation, Operation and Maintenance Procedures**

- Connect to terminal (70V or 100V) and select required tapping in to the transformer.
- Screw the bracket on the wall and fasten the cabinet to the bracket with one screw.
- For optimum performance, always use the correct voltage / power and operate within the frequency limits as stated.
- Do not open loudspeaker when energized.
- This loudspeaker is supplied with two years warranty against defective workmanship.

DNH reserves the right to alter specifications without notice.

