



DNH

HEAD OFFICE, NORWAY
DNH AS

Phone..... + 47 35 98 56 00
Fax..... + 47 35 98 56 10
Web-site..... www.dnh.no

ENGLAND
DNH WW Ltd

Phone..... + 44 1908 275 000
Fax..... + 44 1908 275 100
E-mail..... dnh@dnh.co.uk

GERMANY
DNH GmbH

Phone... + 49 040 6569 30-0
Fax..... + 49 040 6569 30-30
E-mail..... dnh@dnh.de

USA
DNH Speakers Inc

Phone..... + 1 484 494 5790
Fax..... + 1 484 494 5793
E-mail..... dnh@dnhspeakers.com

VES-561-54(T)

ISO 9001 CERTIFIED

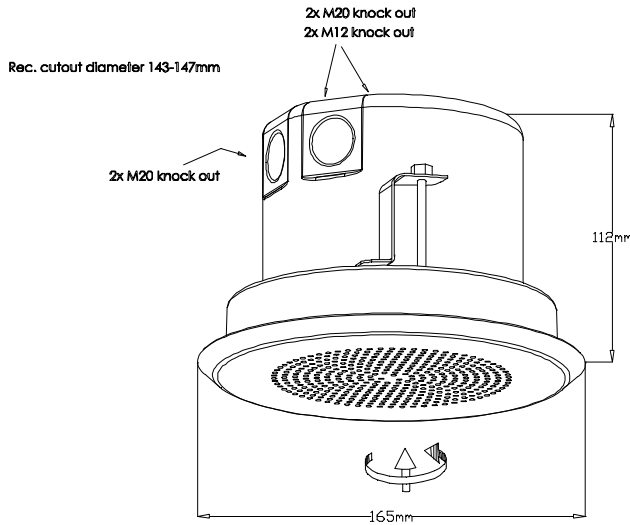

Tested acc. To EN54-24

Type: A
Manufactured by DNH AS
Kragerø Norway
15 1438-CPR-1073

70/100 volt combined transformer Primary connections			
White : Green			70 V
White : Red			100 V
Secondary nominal tapings			
C : 6,0W	6,0 W	Imp	1500 Ohm
C : 3,0W	3,0 W	Imp	3000 Ohm
C : 1,5W	1,5 W	Imp	6000 Ohm
C : 0,5W	0,5 W	Imp	12000 Ohm

Loudspeaker for voice alarm systems for fire detection and fire alarm systems for buildings

Sound pressure levels at 1W/1m P-5/15 PS
SPL vs Freq

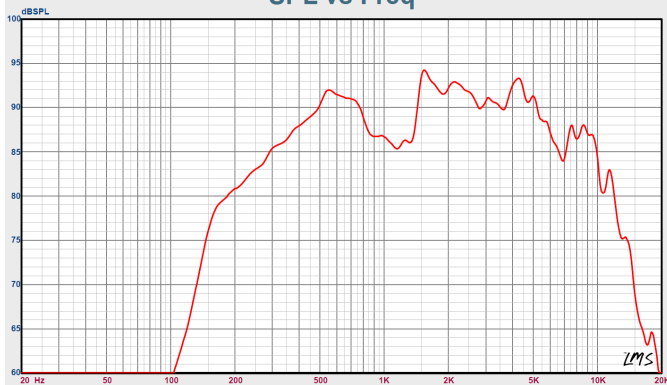

Horizontal / vertical coverage angles (±6dB)

1 Oct. Pink noise	500Hz	180°
1 Oct. Pink noise	1KHz	180°
1 Oct. Pink noise	2KHz	155°
1 Oct. Pink noise	4KHz	80°

Specifications acc. testing CNBOP / DNH

Material / Color	Steel /Alu or Ral 9010
Mounting	3 screws
Termination	Ceramic terminal
Weight w/transformer	1,1 kg
IP-rating	21C / 32C
Max. / min. amb. temp	55°C to -10°C / 90°C to -20°C
Rated / max. power	6 W
Sensitivity 1W/4m	77 dB
SPL 6W/4m	84 dB
Freq. range	180 Hz – 12000Hz
Measurement environment	Standard baffle

Sensitivity 100Hz-10KHz 1/3 Oct. Pink noise 1W/4 Meters

100Hz: 38dB	125Hz: 40dB	160Hz: 47dB
200Hz: 50dB	250Hz: 55dB	315Hz: 60dB
400Hz: 64dB	500Hz: 64dB	630Hz: 63dB
800Hz: 63dB	1KHz: 60dB	1250Hz: 62dB
1600Hz: 67dB	2KHz: 67dB	2500Hz: 66dB
3150Hz: 67dB	4KHz: 67dB	5KHz: 64dB
6300Hz: 62 dB	8KHz: 59dB	10KHz: 57dB

VES-561-54(T) has been tested 100 hours at max power (6W). The model does not deviate more than ± 3 dB from the original test value. The freq. response curve and impedance complies with the original. All SPL tests are performed in an anechoic chamber ($<70m^3$).

Installation, Operation and Maintenance Procedures

- Install the steel box into the cutout hole turning the screws connected to the three hooks, screw clockwise until the ring is fixed to the ceiling.
- Lead cable through cable gland and connect to terminal.
- Turn the grill gently clockwise within the ring until it stops.
- For optimum performance, always use the correct voltage / power and operate within the frequency limits as stated.
- Do not open loudspeaker when energized.
- This loudspeaker is supplied with a two years warranty against defective workmanship.



DNH reserves the right to alter specifications without notice