



# DNH

HEAD OFFICE, NORWAY  
DNH AS

Phone..... + 47 35 98 56 00  
E-mail..... dnh@dnh.no  
Web-Site..... www.dnh.no

ENGLAND  
DNH WW Ltd  
Phone..... + 44 1908 275 000  
Fax..... + 44 1908 275 100  
E-mail..... dnh@dnh.co.uk

GERMANY  
DNH GmbH  
Phone.... + 49 040 6569 30-0  
Fax..... + 49 040 6569 30-30  
E-mail..... dnh@dnh.de

USA  
DNH Speakers Inc  
Phone..... + 1 484 494 5790  
Fax..... + 1 484 494 5793  
E-mail..... dnh@dnhspeakers.com

## DSP-15EExmNL(T)

ISO 9001 CERTIFIED

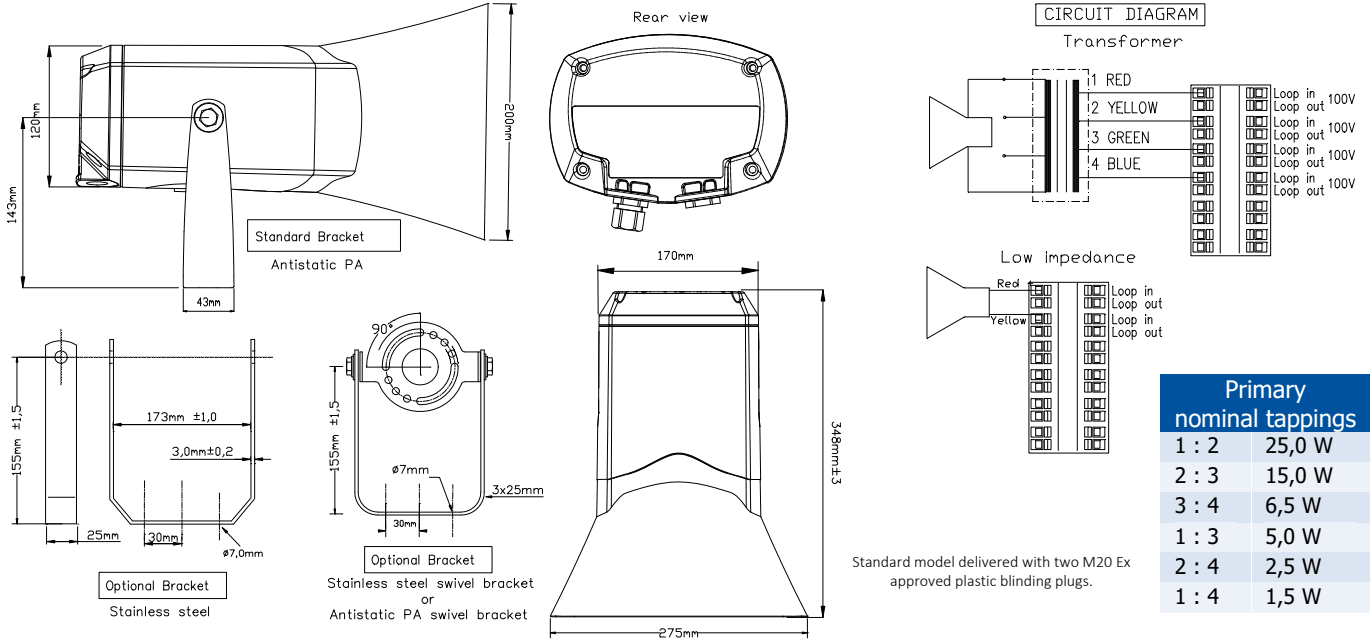

### Ex marking:

- II 2G Ex db eb mb IIB+H<sub>2</sub> / IIC T4 Gb (Zone 1)
- II 2D Ex tb IIIC T105°C Db (Zone 21)

### Certified:

IECEx, ATEX, Inmetro, EAC, CCC, UL/CSA, BV, UKEX, +  
Contact Sales for requested certificates and marking for product.

Sound pressure levels at 1W/1m RAV-67  
SPL vs Freq

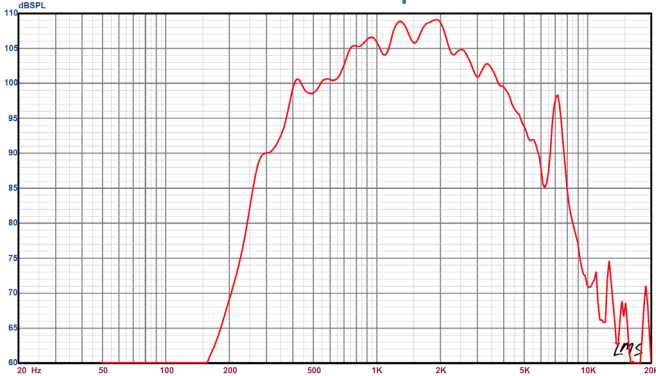

### Specifications

	IIB	IIC
Material / Color	Anti-static PA / Black	
Mounting	Bracket	
Termination	e-chamber, push terminals	
Weight w/transformer	2,8 kg	
IP-rating	66 / 67	
Max. / min. amb. temp	60°C / -50°C	
Rated / max. power	25 W / 30 W	
SPL 1W/1m	109 dB	105 dB
SPL rated power	122 dB	118 dB
Effective freq. range	380 – 7000 Hz	400-7000
Dispersion (-6dB) 1kHz / 4kHz	100° / 30° horizontal	73° / 33°
Options	Impedances, labels, transformers, maintenance free (MF), cables, bracket	

## Installation, Operation and Maintenance Procedures

- Remove lid by four screws, lead cable through the cable gland and connect to terminal with required tapping.
- Every time the back lid is removed, check that the gasket is fitted correctly on to the lid. Do not use any lubricants on the gasket.
- Screw lid back into place by four screws with a torque of 1,8 Nm to assure the IP rating.
- To change the position of the loudspeaker, please adjust the standard U- bracket (by loosening / tightening the screws) as required.
- Use only IECEx/ATEX certified "Ex eb" cable glands and blanking plugs reflecting the same IP rating and temperature range as the loudspeaker.
- Standard model delivered with two M20 Ex approved plastic blinding plugs.
- DSP-15 EExmNL(T) can be supplied with three different bracket systems, according to customer requirements.
- For optimum performance, always use the correct voltage / power and operate within the frequency limits as stated.
- Do not open loudspeaker when energized.
- This loudspeaker is supplied with two years warranty against defective workmanship.

DNH reserves the right to alter specifications without notice.

