



# DNH

HEAD OFFICE, NORWAY  
DNH AS

Phone..... + 47 35 98 56 00  
E-mail..... dnh@dnh.no  
Web-Site..... www.dnh.no

ENGLAND  
DNH WW Ltd

Phone..... + 44 1908 275 000  
Fax..... + 44 1908 275 100  
E-mail..... dnh@dnh.co.uk

GERMANY  
DNH GmbH

Phone... + 49 040 6569 30-0  
Fax..... + 49 040 6569 30-30  
E-mail..... dnh@dnh.de

USA  
DNH Speakers Inc

Phone..... + 1 484 494 5790  
Fax..... + 1 484 494 5793  
E-mail..... dnh@dnhspeakers.com

ISO 9001 CERTIFIED

## DSP-15EExmN(T)MF

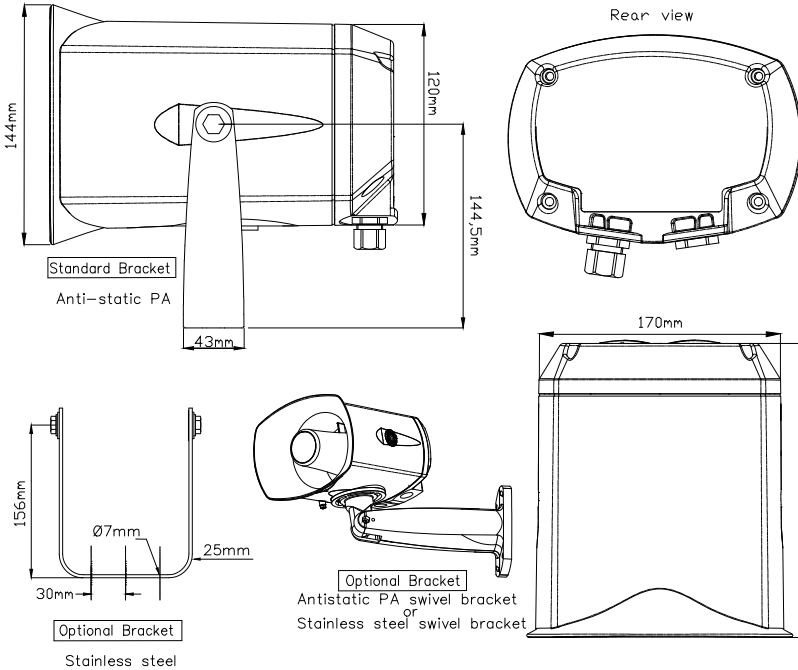

100V Primary nominal tapings	
1 : 2	25,0 W
2 : 3	15,0 W
3 : 4	6,5 W
1 : 3	5,0 W
2 : 4	2,5 W
1 : 4	1,5 W

Delivered with permanent encapsulated cable.

### Ex marking:

- II 2G Ex db eb mb IIB+H<sub>2</sub> / IIC T4 Gb (Zone 1)
- II 2D Ex tb IIIC T105°C Db (Zone 21)

### Certified:

IECEX, ATEX, Inmetro, EAC, CCC, UL/CSA, BV, UKEX, +  
Contact Sales for requested certificates and marking for product.

### Sound pressure levels at 1W/1m RAV67 SPL vs Freq



### Specifications

	IIB	IIC
Material / Color	Anti-static PA / Black	
Mounting	Bracket	
Termination	Cable	
Weight w/transformer	2,6 kg	
IP-rating	66 / 67	
Max. / min. amb. temp	60°C / -50°C	
Rated / max. power	25 W / 30 W	
SPL 1W/1m	106 dB	102 dB
SPL rated power	118 dB	114 dB
Effective freq. range	380 – 8000 Hz	450-7000
Dispersion (-6dB) 1kHz / 4kHz	120° / 37°	105° / 35°
Directivity factor, Q 1kHz/4kHz	4,5 / 9,6	
Options	Impedances, labels, transformers, cables, bracket	

### Installation, Operation and Maintenance Procedures

- Maintenance free model delivered with permanent encapsulated cable.
- To change the position of the loudspeaker, please adjust the standard U-bracket (by loosening / tightening the screws) as required.
- DSP-15EExmN(T) can be supplied with three different bracket systems, according to customer requirements.
- For optimum performance, always use the correct voltage / power and operate within the frequency limits as stated.
- Do not open loudspeaker when energized.
- This loudspeaker is supplied with two years warranty against defective workmanship.

DNH reserves the right to alter specifications without notice.

