



DNH

HEAD OFFICE, NORWAY
DNH AS

Phone..... + 47 35 98 56 00
Fax..... + 47 35 98 56 10
E-mail..... dnh@dnh.no
Web-site..... www.dnh.no

ENGLAND
DNH WW Ltd
Phone..... + 44 1908 275 000
Fax..... + 44 1908 275 100
E-mail..... dnh@dnh.co.uk

GERMANY
DNH GmbH
Phone... + 49 040 6569 30-0
Fax..... + 49 040 6569 30-30
E-mail..... dnh@dnh.de

USA
DNH Speakers Inc
Phone..... + 1 484 494 5790
Fax..... + 1 484 494 5793
E-mail..... dnh@dnhspeakers.com

P3x2P-54(T)

ISO 9001 CERTIFIED

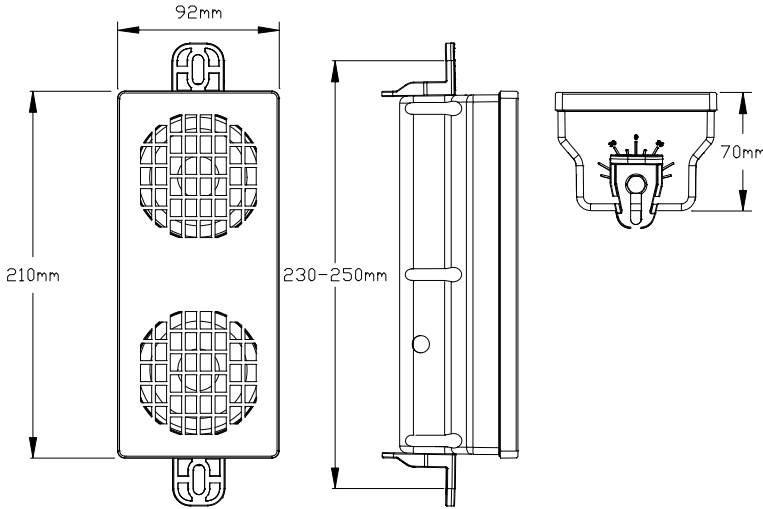

Tested acc. To EN54-24:2008

Type: A

Manufactured by DNH A/S
Kragersø, Norway
12 1438/CPD/0285

70/100 volt combined transformer Primary connections	
White : Green	70 V
White : Red	100 V
Secondary nominal tapings	
Red : Yellow	15 W Imp 670 Ohm
Yellow : Green	7,5 W Imp 1340 Ohm
Green : Blue	3,5 W Imp 2900 Ohm
Red : Green	2,5 W Imp 4000 Ohm
Yellow : Blue	1,2 W Imp 8400 Ohm
Red : Blue	0.75 W Imp 13400 Ohm

Loudspeaker for voice alarm systems for fire detection and fire alarm systems for buildings

Sound pressure levels at 1W/1m

SPL vs Freq



Horizontal / vertical coverage angles (±6dB)

		HCA	VCA
1 Oct. Pink noise	500Hz	360°	360°
1 Oct. Pink noise	1KHz	120°	180°
1 Oct. Pink noise	2KHz	60°	120°
1 Oct. Pink noise	4KHz	30°	85°

Specifications acc. testing CNBOP / DNH

Material / Color	Ronfalin, RAL 7035
Mounting	2 x plastic brackets
Termination	Screw terminal, 0.5m cable
Weight w/transformer	1.0 kg
IP-rating	21C / 54
Working temp	55°C to -10°C / 90°C to -40°C
Rated power	15W
Sensitivity 1W/4m	77 dB
SPL 15W/4m	88 dB / 91dB
Freq. range	100Hz – 18000Hz
Measurement environment	Free-field

Maximum SPL at 6W/4M are the SPL values at 1W/4M increased with 7dB for every 1/3 octave pink noise level.

Sensitivity 100Hz-10KHz 1/3 Oct. Pink noise 1W/4 Meters

100Hz: 35dB	125Hz: 43dB	160Hz: 46dB
200Hz: 57dB	250Hz: 63dB	315Hz: 66dB
400Hz: 65dB	500Hz: 62dB	630Hz: 62dB
800Hz: 64dB	1KHz: 64dB	1250Hz: 66dB
1600Hz: 66dB	2KHz: 70dB	2500Hz: 72dB
3150Hz: 71dB	4KHz: 66dB	5KHz: 68dB
6300Hz: 68 dB	8KHz: 64dB	10KHz: 66dB

P3x2P-54(T) has been tested in 100 hours max power (15W). The model does not deviate more than ± 3 dB from the original test value. The freq. response curve and impedance comply with the original one. All SPL tests are performed in an anechoic chamber (<70m³).

Installation, Operation and Maintenance Procedures

- Connect cable to suitable junction box or terminal.
- If delivered without cable, unscrew lid by six screws, lead cable through cable gland and connect to terminal according required power. Tighten cable gland and screw lid back with 1 Nm to assure IP grade.
- Ensure to use washers in the intended position (between bolt-bracket and between bracket-loudspeaker)
- Screw to wall or ceiling with one screw for each bracket.
- For optimum performance, always use the correct voltage, power and operate within the frequency limits as stated.
- Do not open loudspeaker when energized.
- This loudspeaker is supplied with a two years warranty against defective materials and workmanship.



1438

DNH reserves the right to alter specifications without notice