



DNH

HEAD OFFICE, NORWAY

DNH AS

Phone..... + 47 35 98 56 00

E-mail..... dnh@dnh.no

Web-Site..... www.dnh.no

ENGLAND

DNH WW Ltd

Phone..... + 44 1908 275 000

Fax..... + 44 1908 275 100

E-mail..... dnh@dnh.co.uk

GERMANY

DNH GmbH

Phone... + 49 040 6569 30-0

Fax..... + 49 040 6569 30-30

E-mail..... dnh@dnh.de

BKF-560CR(T)

USA

DNH Speakers Inc

Phone..... + 1 484 494 5790

Fax..... + 1 484 494 5793

E-mail..... dnh@dnhspeakers.com

ISO 9001 CERTIFIED

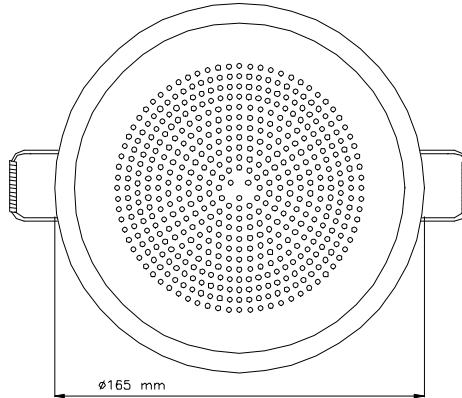
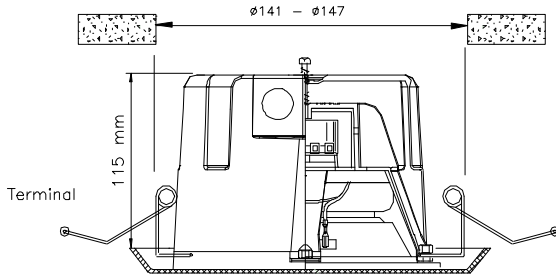
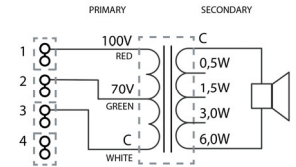

| 70/100 Volt combined transformer | |
|----------------------------------|------------|
| Primary connections | |
| White | Green 70 V |
| White | Red 100 V |
| Secondary nominal tapings | |
| C : 6W | 6,0 W |
| C : 3W | 3,0 W |
| C : 1,5W | 1,5 W |
| C : 0,5W | 0,5 W |

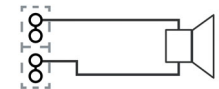

Sound pressure levels at 1W/1m w/P-5/15T
SPL vs Freq

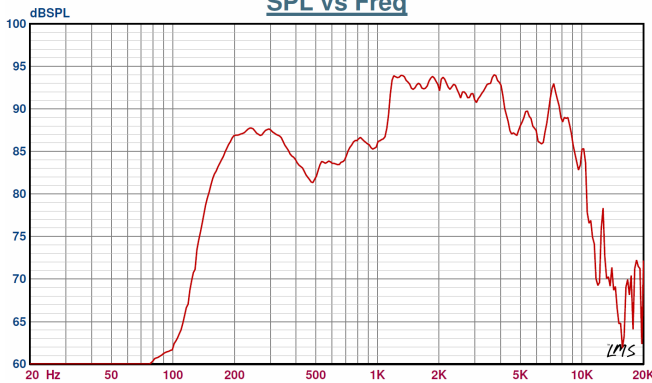

Specifications

| | |
|-------------------------------|----------------------------|
| Material / Color | Aluminum / ABS / RAL9010 |
| Mounting | Springs |
| Termination | Spring clamps |
| Weight w/transformer | 0,74 kg |
| IP-rating | 32 |
| Max. / min. amb. temp | 90°C / -20°C |
| Rated power | 6W |
| SPL 1W/1m | 88 dB |
| SPL rated power | 95 dB |
| Effective freq. range | 150 – 11000 Hz |
| Dispersion (-6dB) 1kHz / 4kHz | 170° / 60° |
| Options | Impedances, colors, labels |

Installation, Operation and Maintenance Procedures

- Remove box by one screw, lead cable trough cable gland, connect to terminal (70V or 100V) and select required tapping on the transformer.
- Install box by one screw and mount the complete loudspeaker into the ceiling by bending back two springs.
- BKF-560CR(T) is designed for clean room applications.
- For optimum performance, always use the correct voltage / power and operate within the frequency limits as stated.
- Do not open loudspeaker when energized.
- This loudspeaker is supplied with two years warranty against defective workmanship.

DNH reserves the right to alter specifications without notice.

