



DNH

HEAD OFFICE, NORWAY
DNH AS

Phone..... + 47 35 98 56 00
E-mail..... dnh@dnh.no
Web-Site..... www.dnh.no

ENGLAND

DNH WW Ltd

Phone..... + 44 1908 275 000
Fax..... + 44 1908 275 100
E-mail..... dnh@dnh.co.uk

GERMANY

DNH GmbH

Phone... + 49 040 6569 30-0
Fax..... + 49 040 6569 30-30
E-mail..... dnh@dnh.de

USA

DNH Speakers Inc

Phone..... + 1 484 494 5790
Fax..... + 1 484 494 5793
E-mail..... dnh@dnhspeakers.com

HP-6C(T)

ISO 9001 CERTIFIED

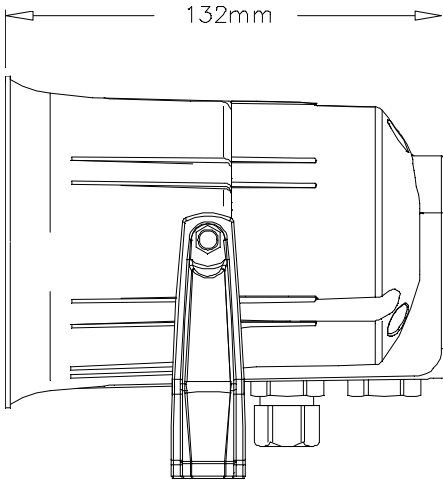

1xM20 cable gland
1xM20 blanking plug
cable diameter
6 – 12mm

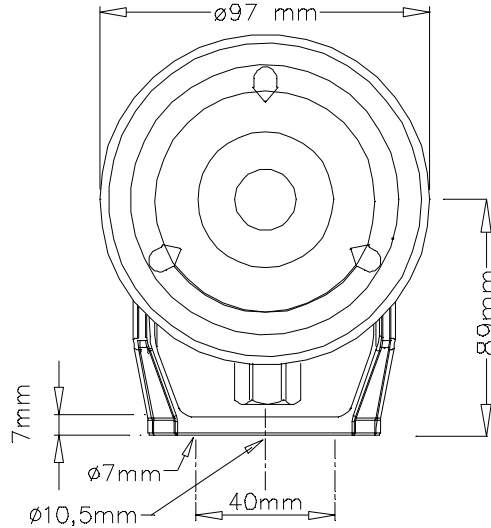

All outside nuts and screws in stainless steel

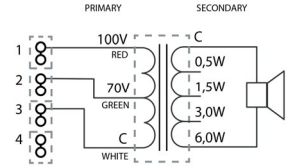

70/100 Volt combined transformer
Primary connections

White : Green 70 V
White : Red 100 V

Secondary nominal tapings

C : 6	6,0 W
C : 3	3,0 W
C : 1,5	1,5 W
C : 0,5	0,5 W

LOW IMPEDANCE

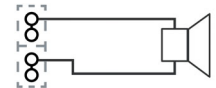

Sound pressure levels at 1W/1m MP-6

SPL vs Freq



Specifications

Material / Color	Polyamide UL94 V0 / RAL 7035
Mounting	Bracket
Termination	Spring clamp
Weight w/transformer	0,62 kg
IP-rating	67
Max. / min. amb. temp	110°C / -40°C
Rated power	6 W
SPL 1W/1m	100 dB
SPL rated power	107 dB
Effective freq. range	300 – 20000 Hz
Dispersion (-6dB) 1kHz / 4kHz	178° / 62°
Directivity factor, Q 1kHz/4kHz	2,0 / 5,8
Options	Impedance, colors, labels

Installation, Operation and Maintenance Procedures

- Remove lid, lead cable through cable gland.
- Connect to terminal 70V: white - green or 100V: white - red.
- Select required power by changing the position of the black wire connected to the transformer; choose according to the label inside the loudspeaker.
- Fasten bracket with 1-3 screws.
- Fasten lid with a torque of 1,5 Nm.
- To change the position of the loudspeaker, please adjust the bracket (by loosening / tightening the screws) as required.
- For optimum performance, always use the correct voltage / power and operate within the frequency limits as stated.
- This loudspeaker is supplied with two years warranty against defective materials and workmanship.

DNH reserves the right to alter specifications without notice.

