



DNH

HEAD OFFICE, NORWAY
DNH AS

Phone..... + 47 35 98 56 00
E-mail..... dnh@dnh.no
Web-Site..... www.dnh.no

ENGLAND
DNH WW Ltd

Phone..... + 44 1908 275 000
Fax..... + 44 1908 275 100
E-mail..... dnh@dnh.co.uk

GERMANY
DNH GmbH

Phone... + 49 040 6569 30-0
Fax..... + 49 040 6569 30-30
E-mail..... dnh@dnh.de

DSP-15(T)

USA
DNH Speakers Inc

Phone..... + 1 484 494 5790
Fax..... + 1 484 494 5793
E-mail..... dnh@dnhspeakers.com

ISO 9001 CERTIFIED

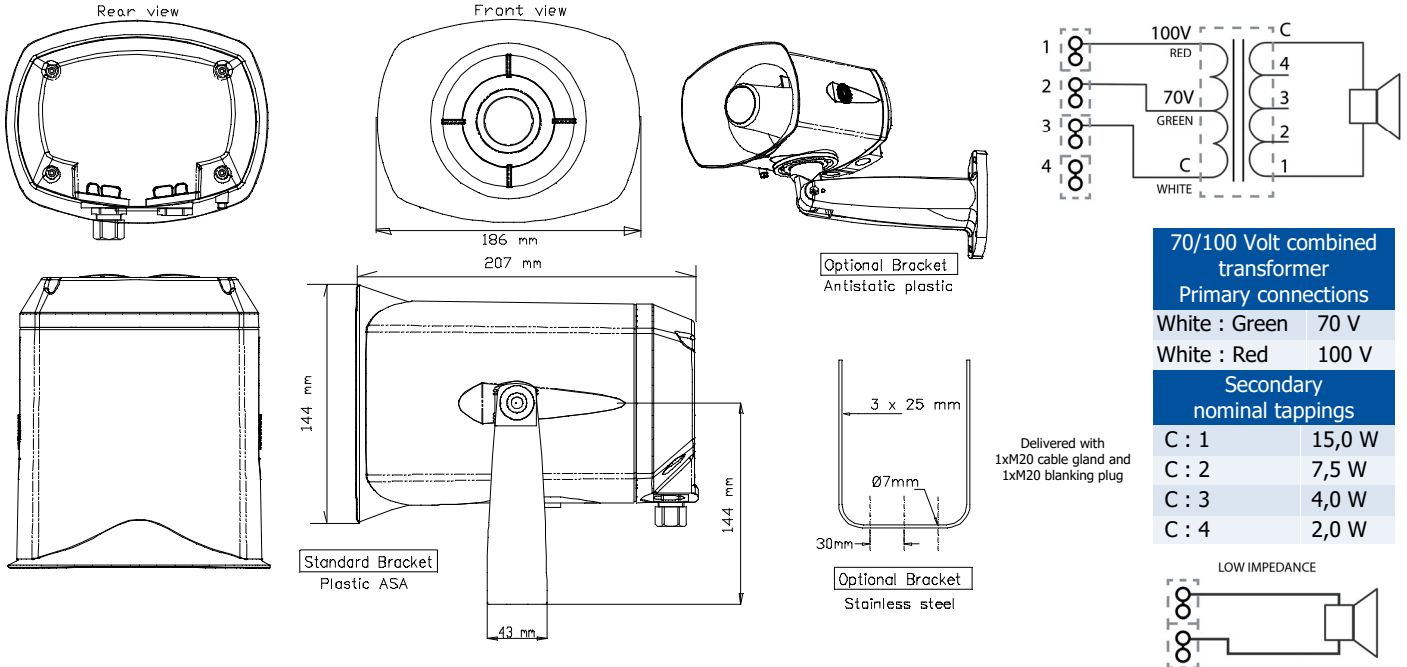

Sound pressure levels at 1W/1m (MP-28-54)
SPL vs Freq

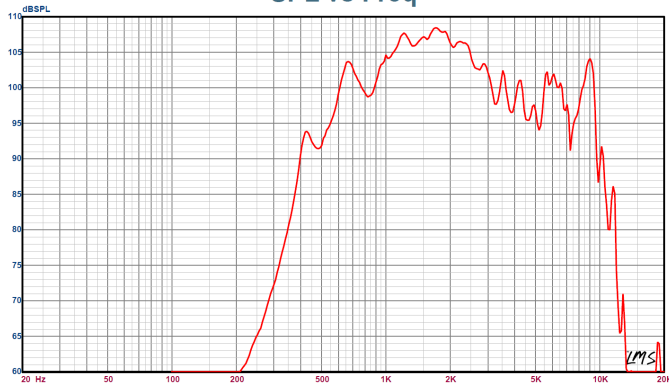

Specifications

Material / Color	ASA / RAL 7035
Mounting	Bracket
Termination	Spring clamp
Weight w/transformer	1,8 kg
IP-rating	67
Max. / min. amb. temp	90°C / -50°C
Rated power	15W
SPL 1W/1m	106 dB
SPL rated power	117 dB
Effective freq. range	550 – 9500 Hz
Dispersion (-6dB) 1kHz / 4kHz	140° / 33°
Directivity factor, Q1kHz/4kHz	1,8 / 7,6
Options	Impedances, colors, labels

Installation, Operation and Maintenance Procedures

- Remove lid by four screws, lead cable through the cable gland and connect to the terminal. (White:Green 70V or White:Red 100V)
- Select required tapping on the transformer.
- Check that the gasket is fitted correctly on to the lid. Do not use any lubricants on the gasket.
- Screw lid back into place by four screws with a torque of 1.3 – 1.8 Nm to assure the IP rating.
- To change the position of the loudspeaker, please adjust the standard U- bracket (by loosening / tightening the screws) as required.
- DSP-15(T) can be supplied with three different bracket systems, according to customer requirements.
- For optimum performance, always use the correct voltage / power and operate within the frequency limits as stated.
- Do not open loudspeaker when energized.
- This loudspeaker is supplied with two years warranty against defective workmanship.

DNH reserves the right to alter specifications without notice.

