



DNH

HEAD OFFICE, NORWAY

DNH AS

Phone..... + 47 35 98 56 00

E-mail..... dnh@dnh.no

Web-Site..... www.dnh.no

ENGLAND

DNH WW Ltd

Phone..... + 44 1908 275 000

Fax..... + 44 1908 275 100

E-mail..... dnh@dnh.co.uk

GERMANY

DNH GmbH

Phone... + 49 040 6569 30-0

Fax..... + 49 040 6569 30-30

E-mail..... dnh@dnh.de

USA

DNH Speakers Inc

Phone..... + 1 484 494 5790

Fax..... + 1 484 494 5793

E-mail..... dnh@dnhspeakers.com

H-66(T)

ISO 9001 CERTIFIED

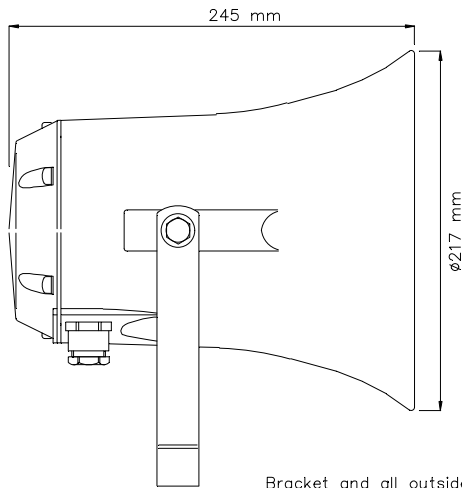

Bracket and all outside nuts and screws in stainless steel.

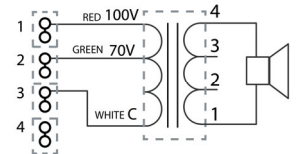
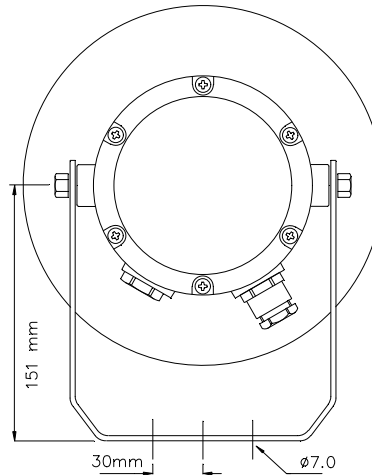

70/100 Volt combined transformer	
Primary connections	
White : Green	70 V
White : Red	100 V
Secondary nominal tapings	
1 : 4	25,0W
1 : 3	12,5W
2 : 4	8,0W
1 : 2	7,0 W
3 : 4	3,0W
2 : 3	1,7W

LOW IMPEDANCE

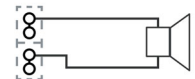

Sound pressure levels at 1W/1m

SPL vs Freq

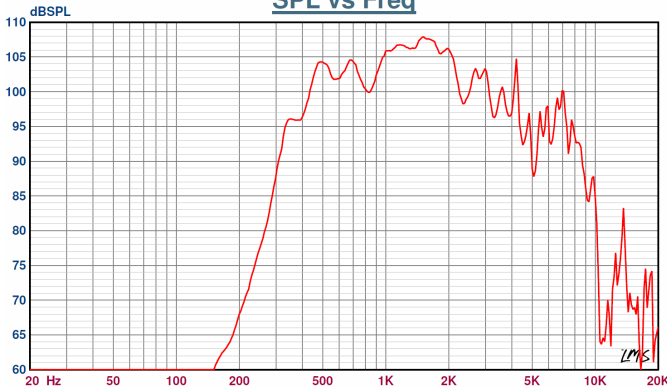

Specifications

Material / Color	Aluminum alloy SS4261 / RAL 7035
Mounting	Bracket
Termination	Spring clamp
Weight w/transformer	3,8 kg
IP-rating	67
Max. / min. amb. temp	110°C / -50°C
Rated power	25W
SPL 1W/1m	108 dB
SPL rated power	121 dB
Effective freq. range	300 – 9000 Hz
Dispersion (-6dB) 1kHz / 4kHz	125° / 35°
Options	Impedances, colors, labels

Installation, Operation and Maintenance Procedures

- Unscrew lid, lead cable through cable gland and connect to terminal (70V or 100V).
- Tight cable gland and screw lid back on with 2,5 Nm to assure IP grade.
- Fasten the bracket with three screws and ensure to use all washers in the intended position. (To isolate the main body from the bracket).
- To change the position of the loudspeaker, please adjust the bracket (by loosening / tightening the screws) as required.
- The aluminum surface of the loudspeaker should be treated regularly with paint at the same interval as with other similar outdoor equipment.
- For optimum performance, always use the correct voltage / power and operate within the frequency limits as stated.
- Do not open loudspeaker when energized.
- This loudspeaker is supplied with two years warranty against defective workmanship.

DNH reserves the right to alter specifications without notice.

