



# DNH

HEAD OFFICE, NORWAY

**DNH AS**

Phone..... + 47 35 98 56 00

E-mail..... dnh@dnh.no

Web-Site..... www.dnh.no

ENGLAND

**DNH WW Ltd**

Phone..... + 44 1908 275 000

Fax..... + 44 1908 275 100

E-mail..... dnh@dnh.co.uk

GERMANY

**DNH GmbH**

Phone... + 49 040 6569 30-0

Fax..... + 49 040 6569 30-30

E-mail..... dnh@dnh.de

USA

**DNH Speakers Inc**

Phone..... + 1 484 494 5790

Fax..... + 1 484 494 5793

E-mail..... dnh@dnhspeakers.com

## DST-100-MED

ISO 9001 CERTIFIED

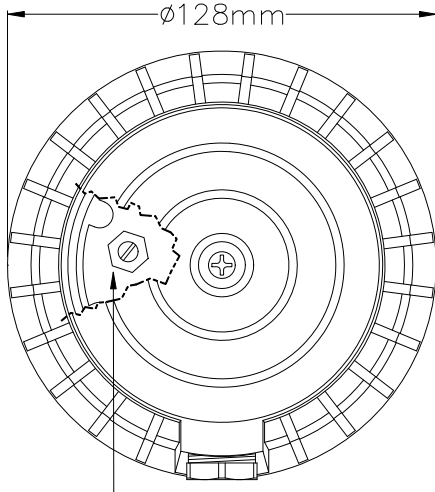

Tapping selector

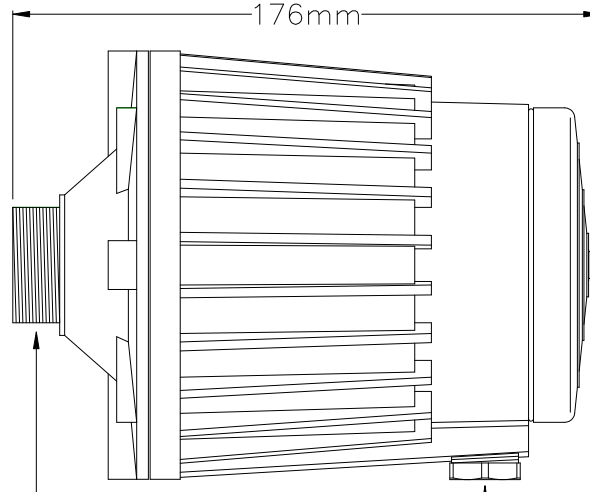

UNEF 1 3/8 - 18

Cable Entry  
M20  
Cable diameter  
8 - 13mm

100 Volt line Secondary switch tapings	
1/1	100 W
1/2	60 W
1/4	30 W
1/8	15 W
1/16	7,5 W

Sound pressure levels at 1W/1m w / DH-50

**SPL vs Freq**

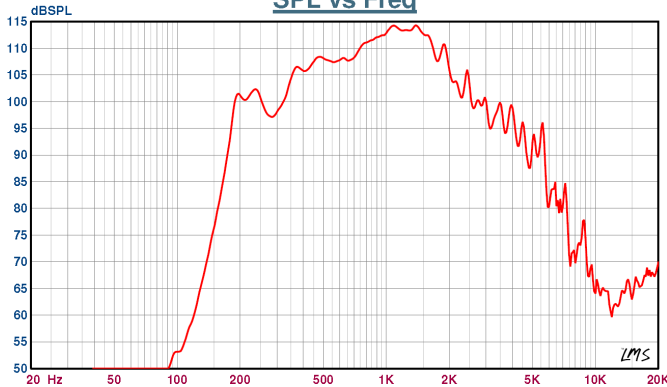

Specifications w / DH-50

Material / Color	Aluminum alloy / RAL 7035
Mounting	Threaded UNEF 1 3/8 - 18
Termination	Screw terminal
Weight	2,4 kg
IP-rating	67
Max. / min. amb. temp	150°C / -50°C
Rated power	100 W
SPL 1W/1m	112 dB
SPL rated power	132 dB
Effective freq. range	200 - 5500 Hz
Dispersion (-6dB) 1kHz / 4kHz	42° / 25°
Directivity factor, Q1kHz/4kHz	8,5 / 14,2
Safe Compass Distance	5 m
Options	50 V or 70 V line, colors

### Installation, Operation and Maintenance Procedures

- Driver unit DS-100 uses UNEF 1 3/8-18 thread.
- With internal temperature fuse.
- Audio specifications listed are for the driver in combination with DNH's DH-50 flare. DH-30 flare is also available.
- Remove lid, lead cable trough cable gland, and connect cable to terminal.
- Choose required power with tapping selector.
- Tighten cable gland and screw lid back on 2 Nm.
- For optimum performance, always use the correct voltage / power and operate within the frequency limits as stated.
- Do not open loudspeaker when energized.
- This loudspeaker is supplied with two years warranty against defective workmanship.

DNH reserves the right to alter specifications without notice.

