



# DNH

HEAD OFFICE, NORWAY  
DNH AS

Phone..... + 47 35 98 56 00  
E-mail..... dnh@dnh.no  
Web-site..... www.dnh.no

ENGLAND  
DNH WW Ltd

Phone..... + 44 1908 275 000  
Fax..... + 44 1908 275 100  
E-mail..... dnh@dnh.co.uk

GERMANY  
DNH GmbH

Phone... + 49 040 6569 30-0  
Fax..... + 49 040 6569 30-30  
E-mail..... dnh@dnh.de

USA  
DNH Speakers Inc

Phone..... + 1 484 494 5790  
Fax..... + 1 484 494 5793  
E-mail..... dnh@dnhspeakers.com

## VES-561-54T-MED

ISO 9001 CERTIFIED

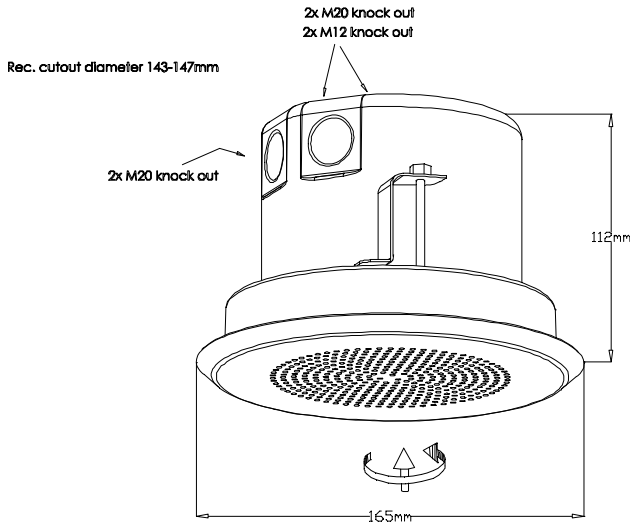

**Tested acc. To EN54-24**

**Type: A**  
**Manufactured by DNH AS**  
**Kragerø Norway**  
**15 1438-CPR-0220**

70/100 volt combined transformer  
Primary connections

White : Green	70 V
White : Red	100 V

Secondary  
nominal tapings

C : 6,0W	6,0 W	Imp	1500 Ohm
C : 3,0W	3,0 W	Imp	3000 Ohm
C : 1,5W	1,5 W	Imp	6000 Ohm
C : 0,5W	0,5 W	Imp	12000 Ohm

Loudspeaker for voice alarm systems for fire detection and fire alarm systems for buildings

Sound pressure levels at 1W/1m P-5/15 PS

SPL vs Freq

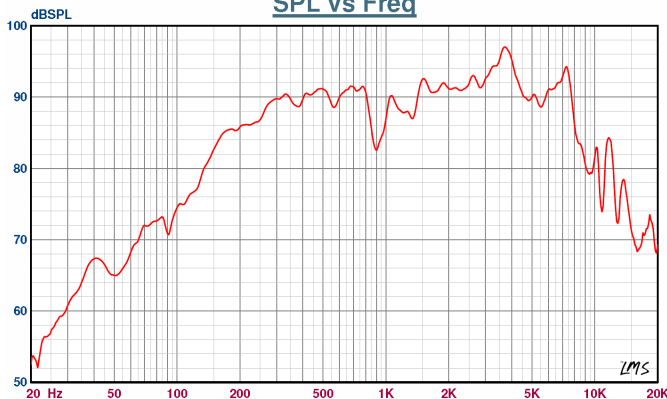

Horizontal / vertical coverage angles ( $\pm 6$ dB)

1 Oct. Pink noise	500Hz	180°
1 Oct. Pink noise	1KHz	180°
1 Oct. Pink noise	2KHz	155°
1 Oct. Pink noise	4KHz	80°

Specifications acc. testing CNBOP / DNH

Material / Color	Steel /Alu or Ral 9010
Mounting	3 screws
Termination	Screw terminal
Weight w/transformer	1,1 kg
IP-rating	32C
Max. / min. amb. temp	55°C to -10°C / 90°C to -20°C
Rated / max. power	6 W
Sensitivity 1W/4m	77 dB
SPL 6W/4m	84 dB
Freq. range	100 Hz – 13000Hz
Safe Compass Distance	5 m
Measurement environment	Standard baffle

Sensitivity 100Hz-10KHz 1/3 Oct. Pink noise 1W/4 Meters

100Hz: 38dB	125Hz: 40dB	160Hz: 47dB
200Hz: 50dB	250Hz: 55dB	315Hz: 60dB
400Hz: 64dB	500Hz: 64dB	630Hz: 63dB
800Hz: 63dB	1KHz: 60dB	1250Hz: 62dB
1600Hz: 67dB	2KHz: 67dB	2500Hz: 66dB
3150Hz: 67dB	4KHz: 67dB	5KHz: 64dB
6300Hz: 62 dB	8KHz: 59dB	10KHz: 57dB

VES-561-54(T) has been tested 100 hours at max power (6W). The model does not deviate more than  $\pm 3$  dB from the original test value. The freq. response curve and impedance complies with the original. All SPL tests are performed in an anechoic chamber ( $<70m^3$ ).

### Installation, Operation and Maintenance Procedures

- Install the steel box into the cutout hole turning the screws connected to the three hooks, screw clockwise until the ring is fixed to the ceiling.
- Lead cable through cable gland and connect to terminal.
- Turn the grill gently clockwise within the ring until it stops.
- For optimum performance, always use the correct voltage / power and operate within the frequency limits as stated.
- Do not open loudspeaker when energized.
- This loudspeaker is supplied with a two years warranty against defective workmanship.



DNH reserves the right to alter specifications without notice